

FULLY Automatic POWER BELT TYPE

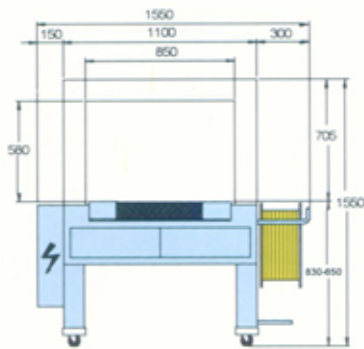

FEATURES:

- Equipped With Two Photocells (2HT)
- No-pack, No-strap, Photo-electric sensor and no drive power belt
- Timing belt transmit
- Easy maintenance by raised-up top cover
- Supply a circuitry to combine fore & hind of conveyor.
- Air compression is acceptable.
- 110V/220V single phase are available.

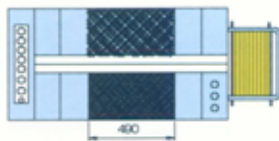

Specifications:

MODEL	JN85PB
Power Supply	110V/220V/1PHASE 220/380/415/3PHASE
Starp Cycle Speed	30 Starps /60HZ
Power Belt Speed	22.3m/60sec
Machine Size	1550mm(W)X640mm(D)X1550mm(H)
Machine Weight	330kg
Mini Package Size	300mm(W)X30mm(H)
Max. Package Size	850mm(W)X580mm(H)
Tension Strength	0.5 To 70.0(kg)
Strap Width	8mm-19mm(Change kits and adj)